

## TMD EC

### Direct Drive Motor

Double inlet series with direct drive motor

New high Efficiency Fan



EC —  
TECH  





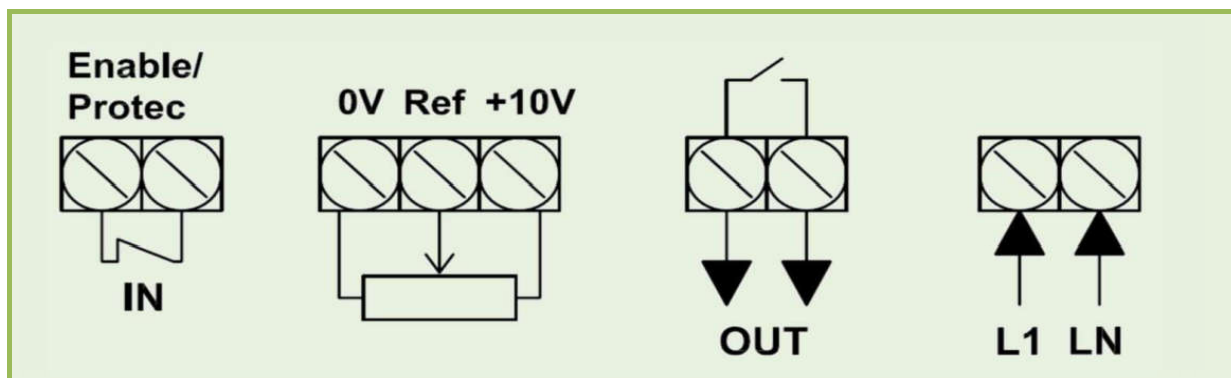
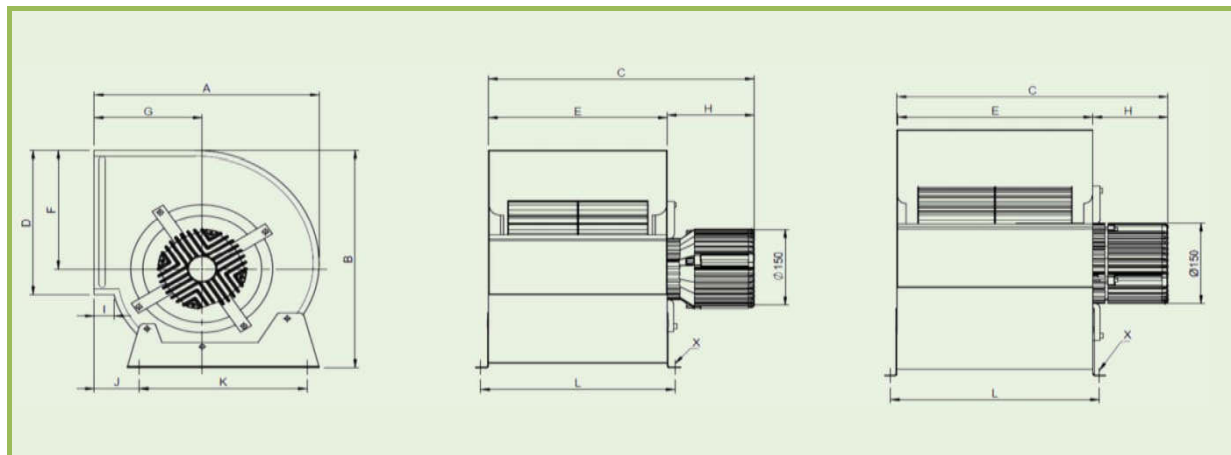

FAN	A	B	C	D	E	G	F	H	I	J	K	L	X
TMD EC 7/7-16	307	326	377	209	232	180	146	145	27	55	228	258	10x15
TMD EC 9/7-11	375	400	395	265	250	218	180	145	33	75	280	273	10x15
TMD EC 9/7-16	375	400	410	265	250	218	180	160	33	75	280	273	10x15
TMD EC 9/9-11	375	400	443	265	298	218	180	145	33	75	280	324	10x15
TMD EC 9/9-16	375	400	448	265	298	218	180	150	33	75	280	324	10x15
TMD EC 10/8-11	427	452	404	290	274	245	207	130	38	82	320	296	10x15
TMD EC 10/8-16	427	452	399	290	274	245	207	125	38	82	320	296	10x15
TMD EC 10/10-11	427	452	446	290	326	245	207	120	38	82	320	348	10x15
TMD EC 10/10-16	427	452	446	290	326	245	207	120	38	82	320	348	10x15
TMD EC 12/9-11	498	530	444	342	309	292	236	135	38	82	400	330	10x16
TMD EC 12/9-14	498	530	444	342	309	292	236	135	38	82	400	330	10x16
TMD EC 12/12-11	498	530	476	342	386	292	236	90	38	82	400	406	10x16
TMD EC 12/12-14	498	530	476	342	386	292	236	90	38	82	400	406	10x16
TMD EC 15/15-09	578	622	553	404	473	343	271	80	38	94	460	500	12x20



TMD EC 7/7-16

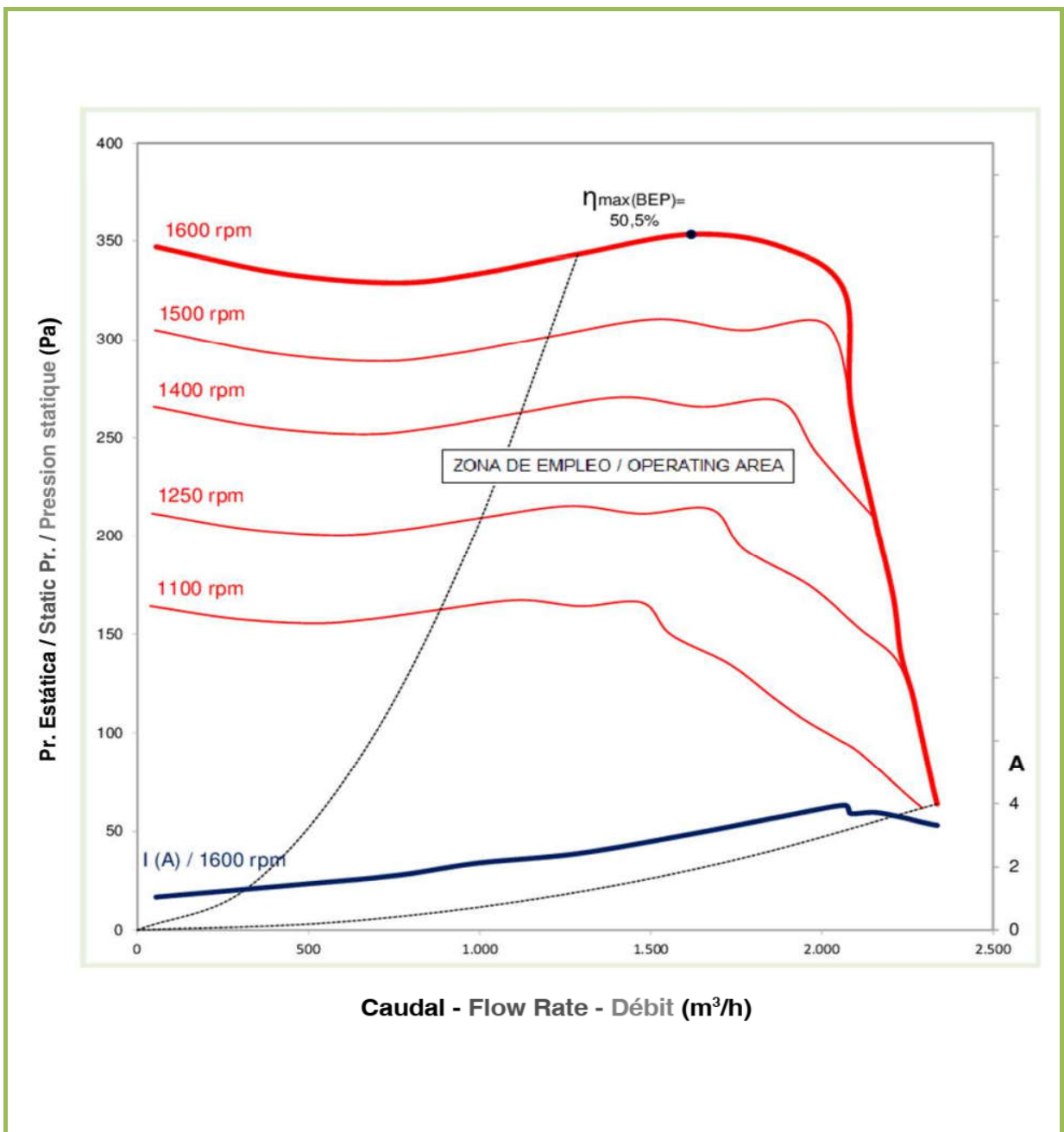

Max. electric power input	Revolutions Max	Intensity Max	Voltage Max	Max air flow	Max static pressure	Weight
P max W	RPM max (min <sup>-1</sup> )	I max (A) 220V 240V	Tension V -50 Hz	m <sup>3</sup> /h	Pa	Kg
553	1600	3,9	230V±10%	2336	353,2	10



## TMD EC 9/7-11



Max. electric power input	Revolutions Max	Intensity Max	Voltage Max	Max air flow	Max static pressure	Weight
P max W	RPM max (min <sup>-1</sup> )	I max (A) 220V 240V	Tension V -50 Hz	m <sup>3</sup> /h	Pa	Kg
418	1100	3,0	230V±10%	2095	282	12,3

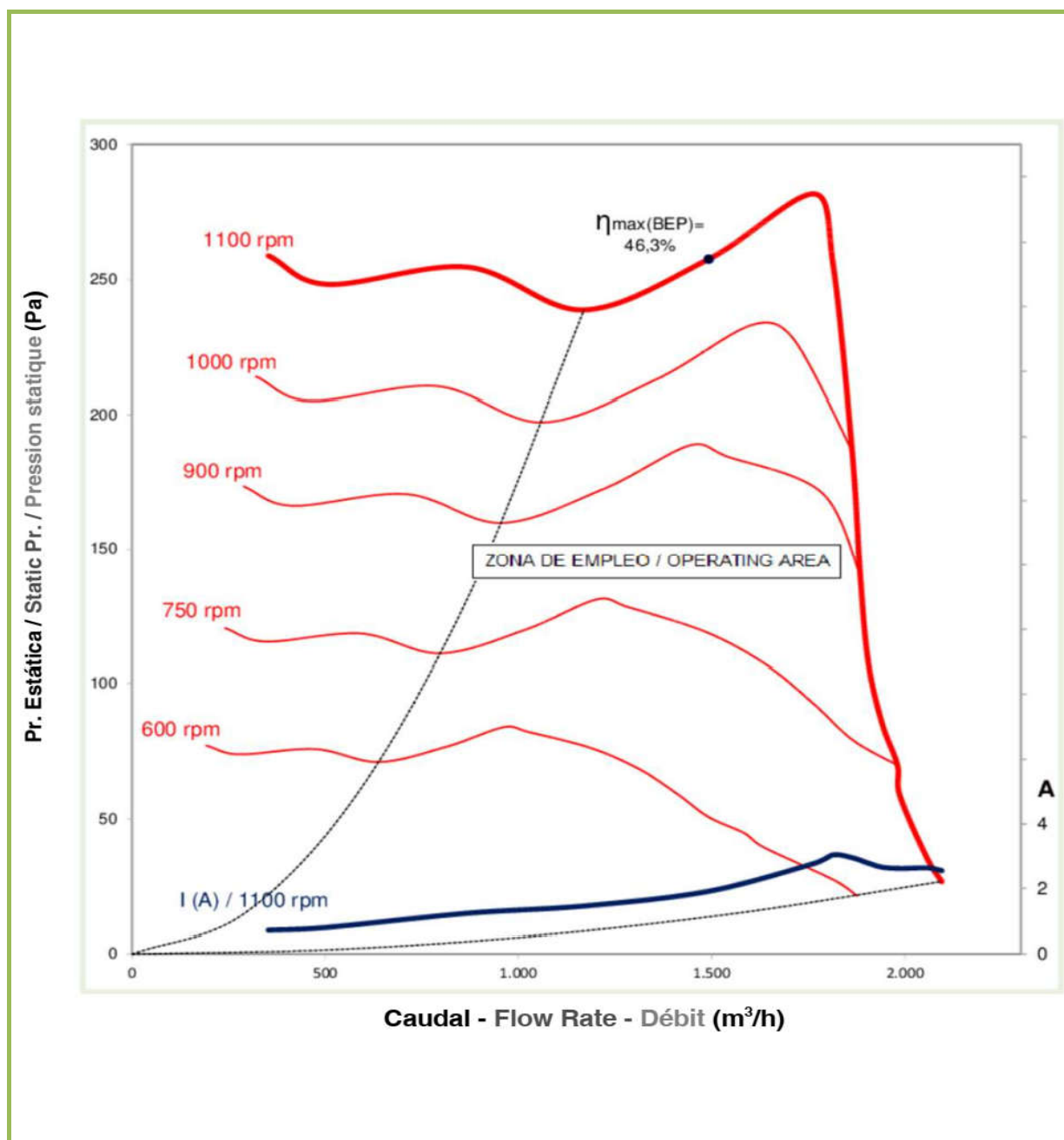

TMD EC 9/7-16



Max. electric power input	Revolutions Max	Intensity Max	Voltage Max	Max air flow	Max static pressure	Weight
P max W	RPM max (min <sup>-1</sup> )	I max (A) 220V 240V	Tension V -50 Hz	m <sup>3</sup> /h	Pa	Kg
978	1600	6,6	230V±10%	3136	586,6	13,8

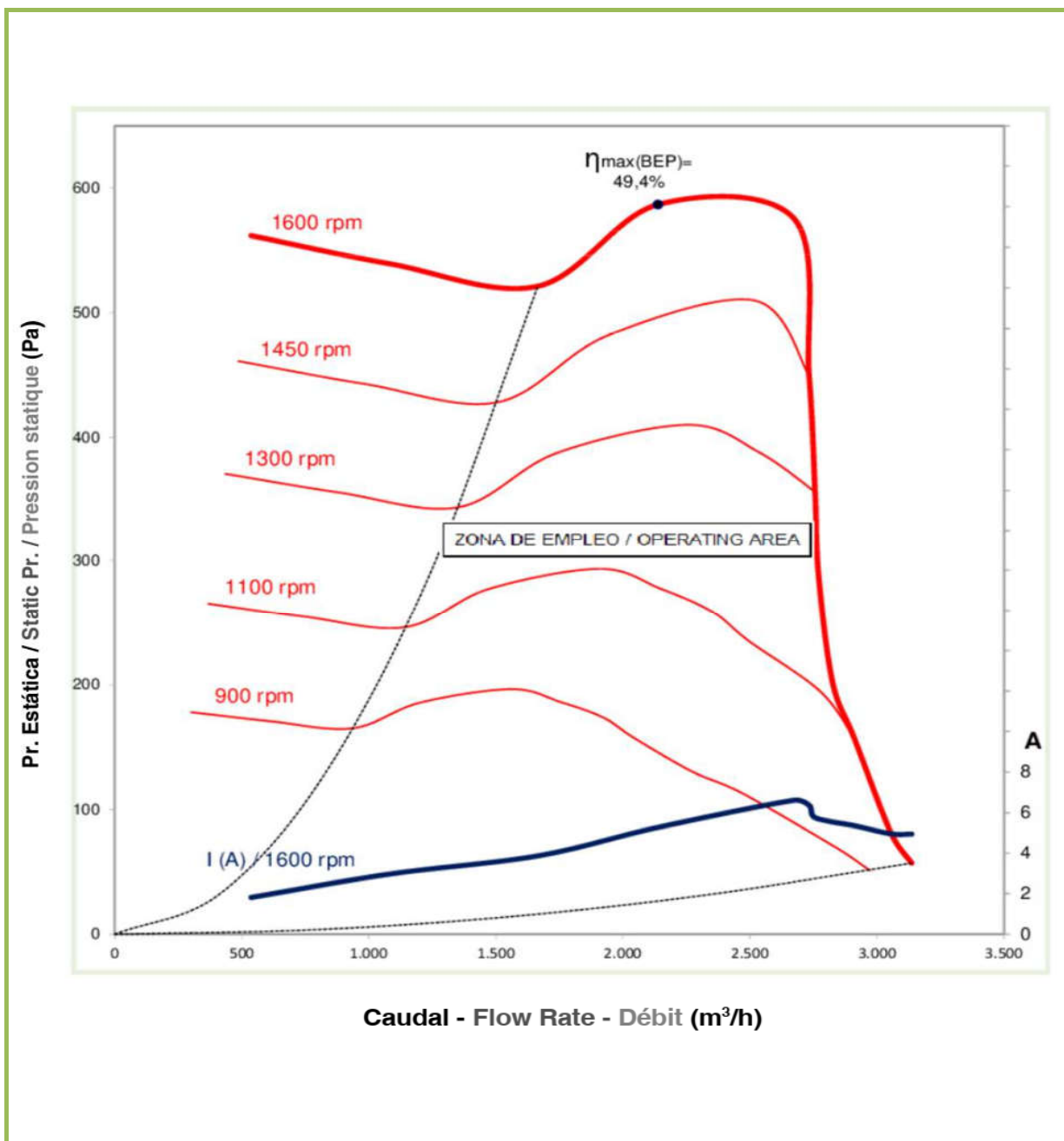

## TMD EC 9/9-11



Max. electric power input	Revolutions Max	Intensity Max	Voltage Max	Max air flow	Max static pressure	Weight
P max W	RPM max (min <sup>-1</sup> )	I max (A) 220V 240V	Tension V -50 Hz	m <sup>3</sup> /h	Pa	Kg
411	1100	3,0	230V±10%	2355	263,4	12,9

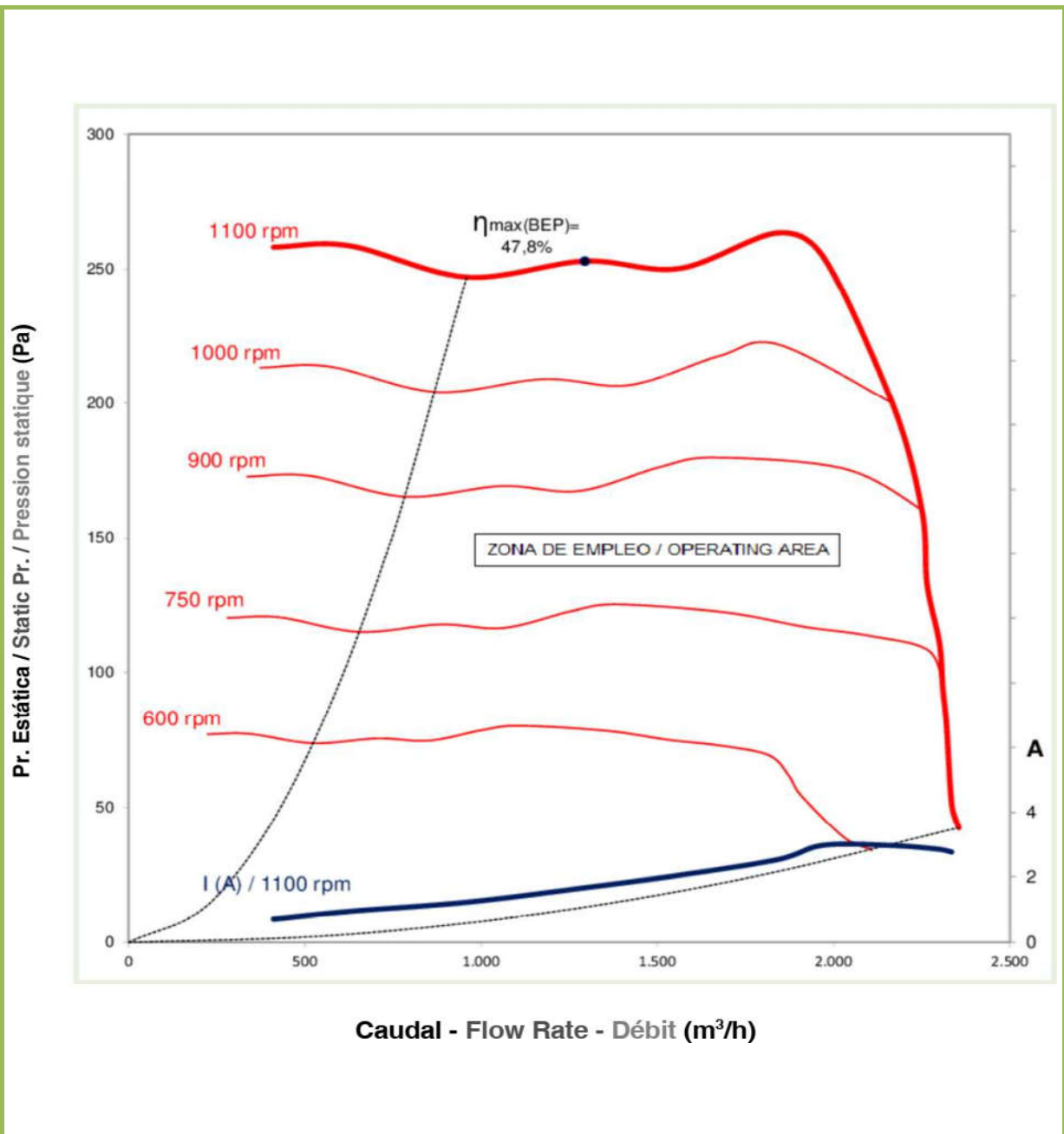

## TMD EC 9/9-16



Max. electric power input	Revolutions Max	Intensity Max	Voltage Max	Max air flow	Max static pressure	Weight
P max W	RPM max (min <sup>-1</sup> )	I max (A) 220V 240V	Tension V -50 Hz	m <sup>3</sup> /h	Pa	Kg
957	1600	6,4	230V±10%	3479	561,8	14,4

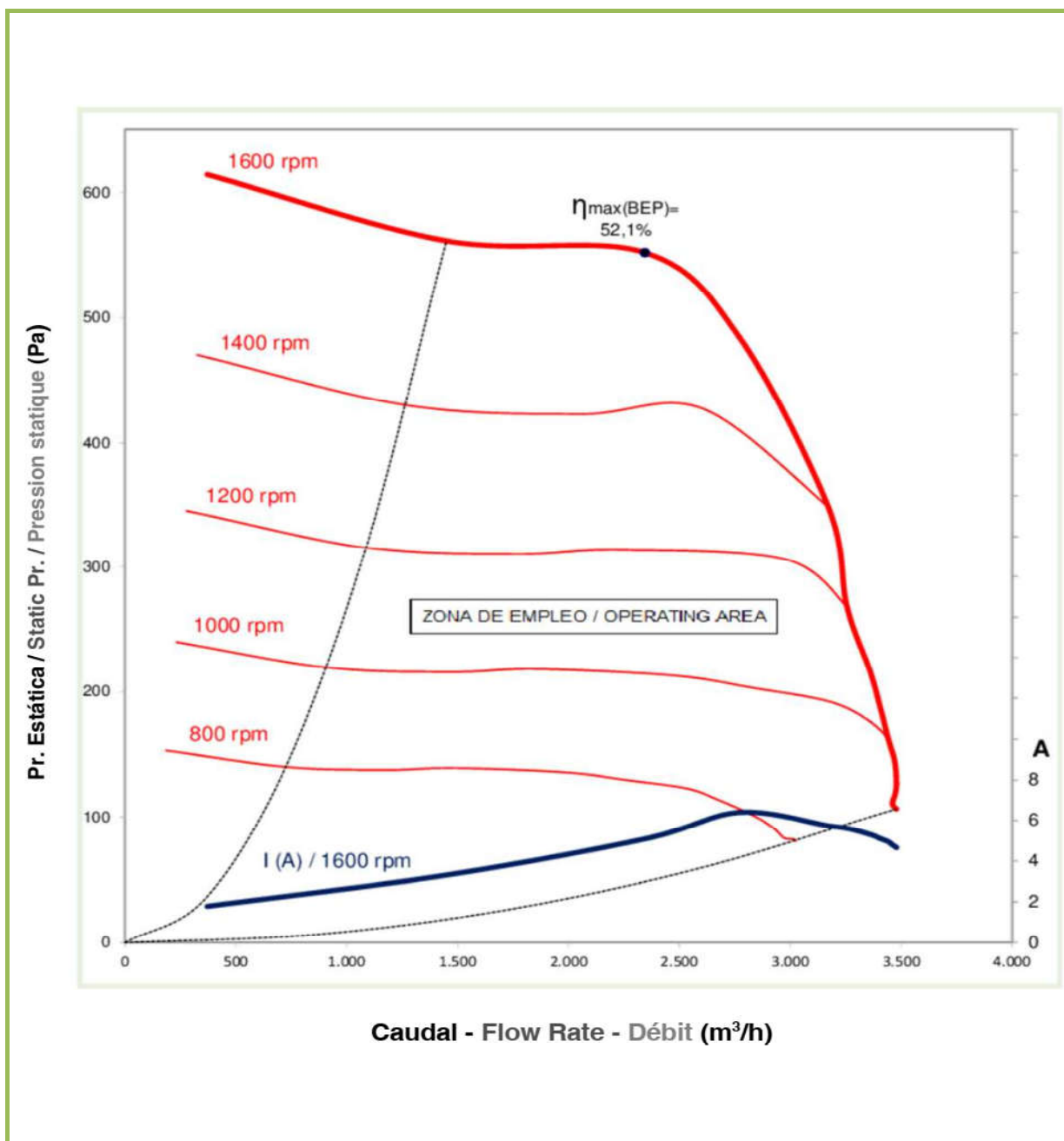

TMD EC 10/8-11



Max. electric power input	Revolutions Max	Intensity Max	Voltage Max	Max air flow	Max static pressure	Weight
P max W	RPM max (min <sup>-1</sup> )	I max (A) 220V 240V	Tension V -50 Hz	m <sup>3</sup> /h	Pa	Kg
738	1100	5,3	230V±10%	3007	361,9	15,2

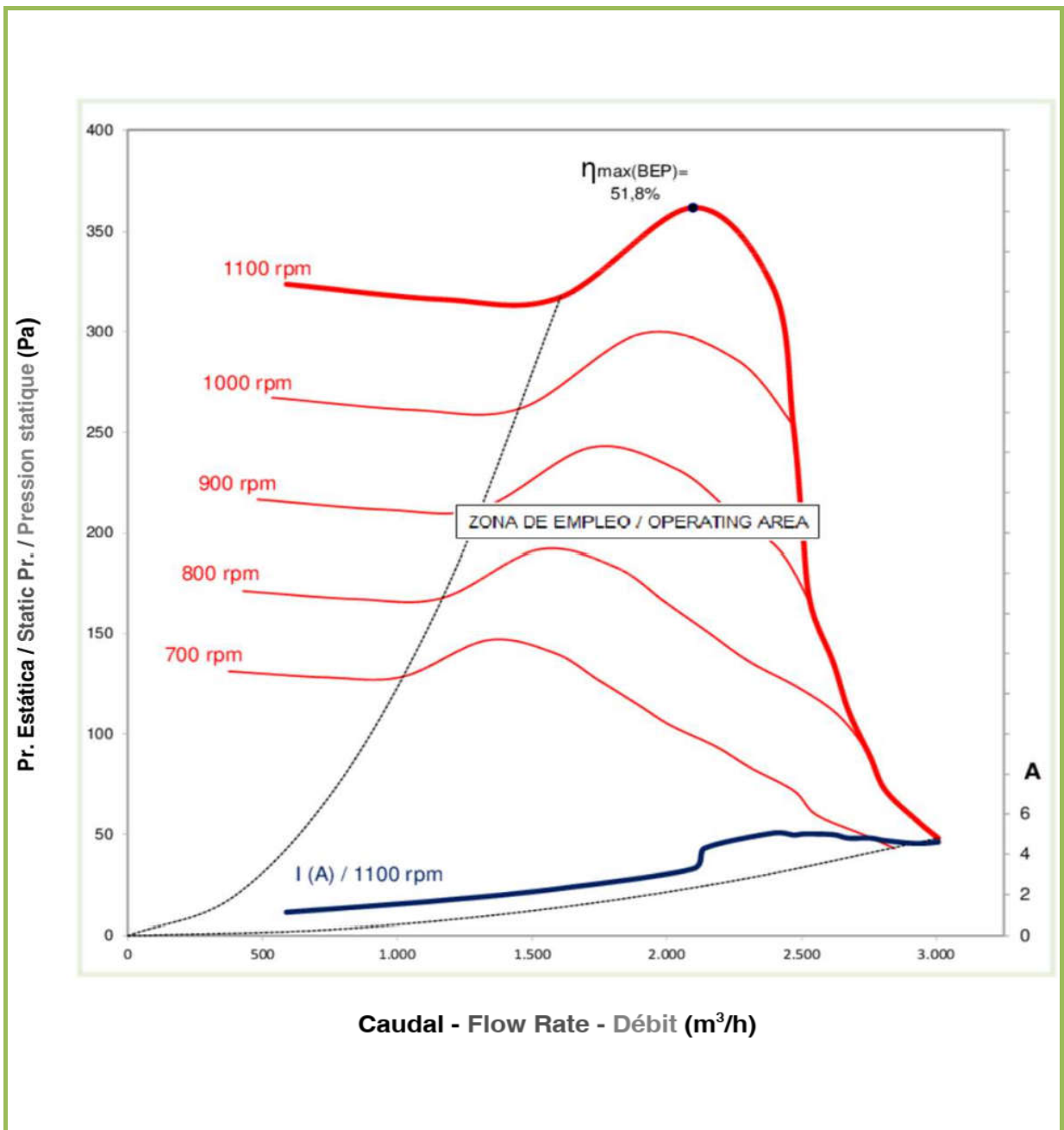



TMD EC 10/8-16



Max. electric power input	Revolutions Max	Intensity Max	Voltage Max	Max air flow	Max static pressure	Weight
P max W	RPM max (min <sup>-1</sup> )	I max (A) 220V 240V	Tension V -50 Hz	m <sup>3</sup> /h	Pa	Kg
2057	1600	13,0	230V±10%	4345	761,7	17,5

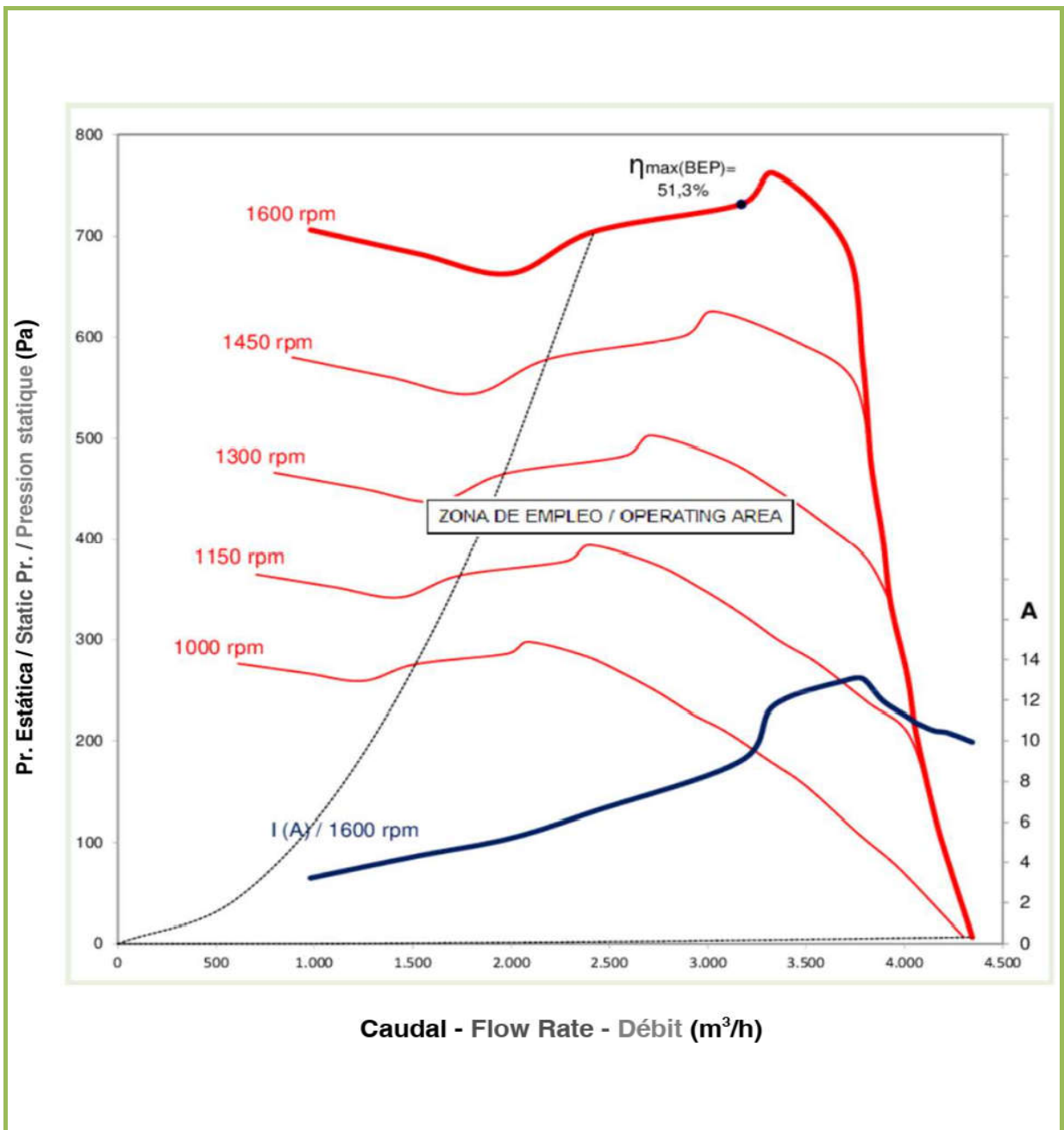

**TMD EC 10/10-11**



Max. electric power input	Revolutions Max	Intensity Max	Voltage Max	Max air flow	Max static pressure	Weight
P max W	RPM max (min <sup>-1</sup> )	I max (A) 220V 240V	Tension V -50 Hz	m <sup>3</sup> /h	Pa	Kg
744	1100	4,9	230V±10%	3684	346,5	15,8

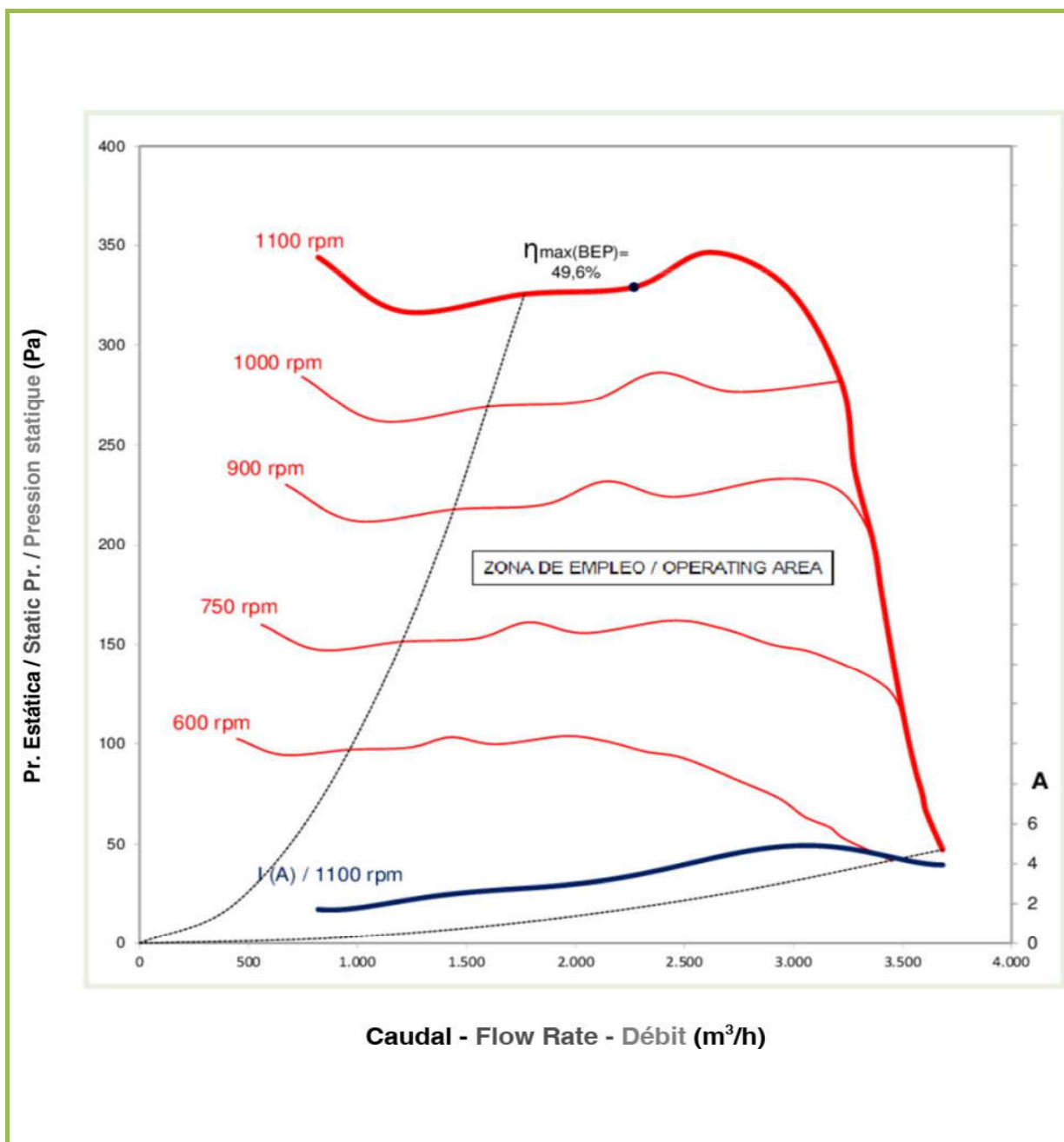

TMD EC 10/10-16



Max. electric power input	Revolutions Max	Intensity Max	Voltage Max	Max air flow	Max static pressure	Weight
P max W	RPM max (min <sup>-1</sup> )	I max (A) 220V 240V	Tension V -50 Hz	m <sup>3</sup> /h	Pa	Kg
2012	1600	13,0	230V±10%	4803	712,4	18,1

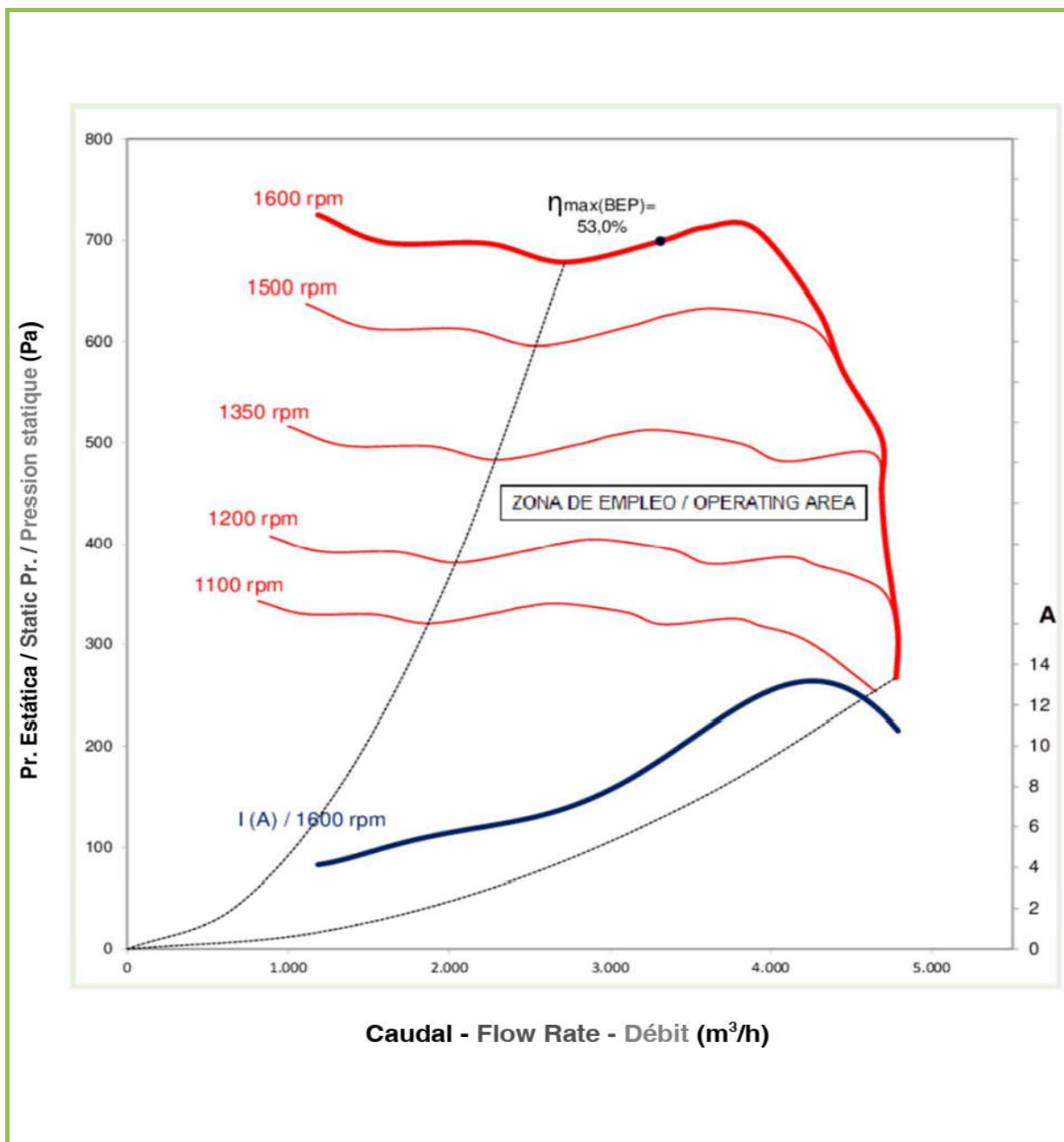

TMD EC 12/9-11



Max. electric power input	Revolutions Max	Intensity Max	Voltage Max	Max air flow	Max static pressure	Weight
P max W	RPM max (min <sup>-1</sup> )	I max (A) 220V 240V	Tension V -50 Hz	m <sup>3</sup> /h	Pa	Kg
1535	1100	9,7	230V±10%	5603	400	20,5

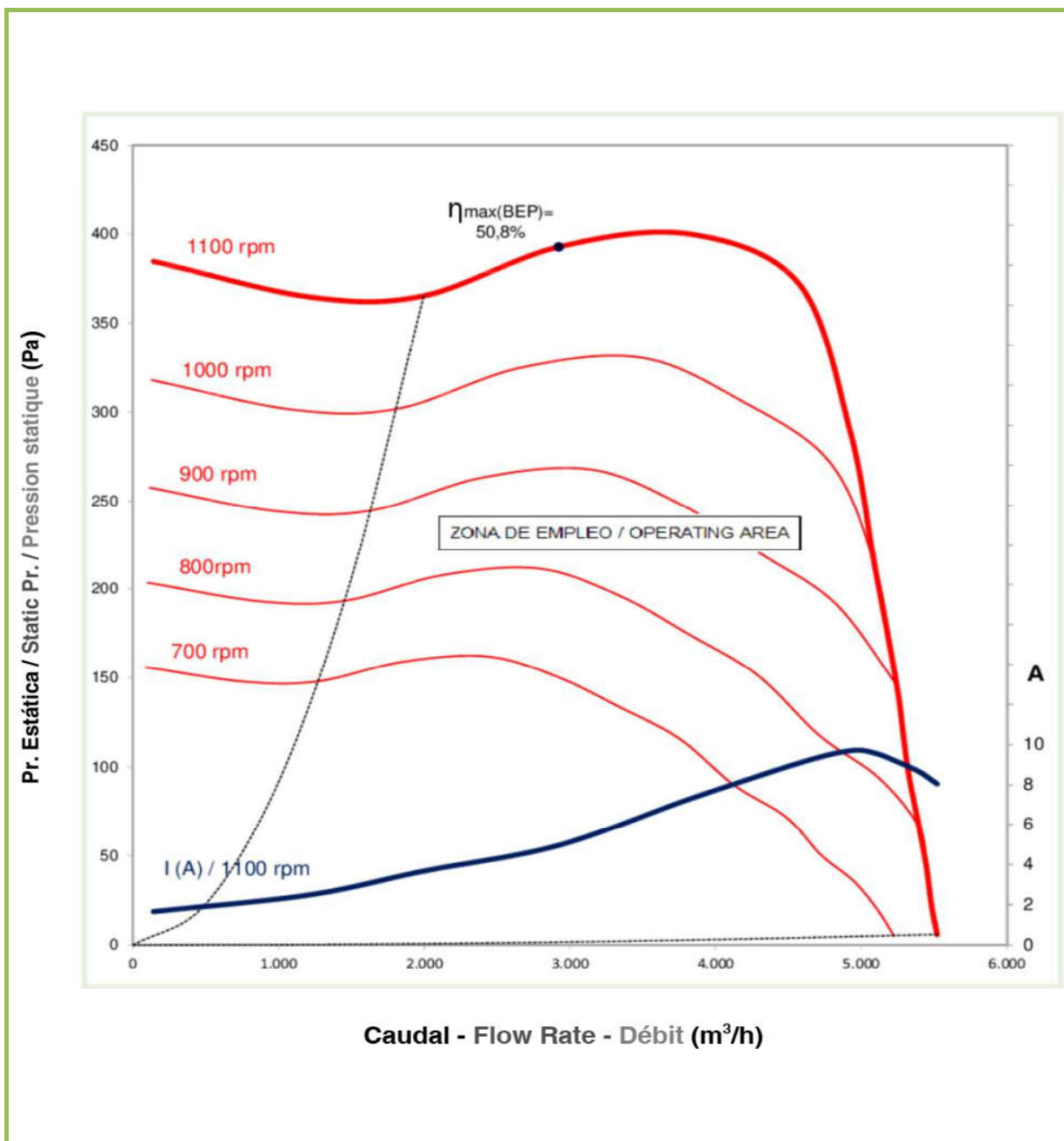

**TMD EC 12/9-14**

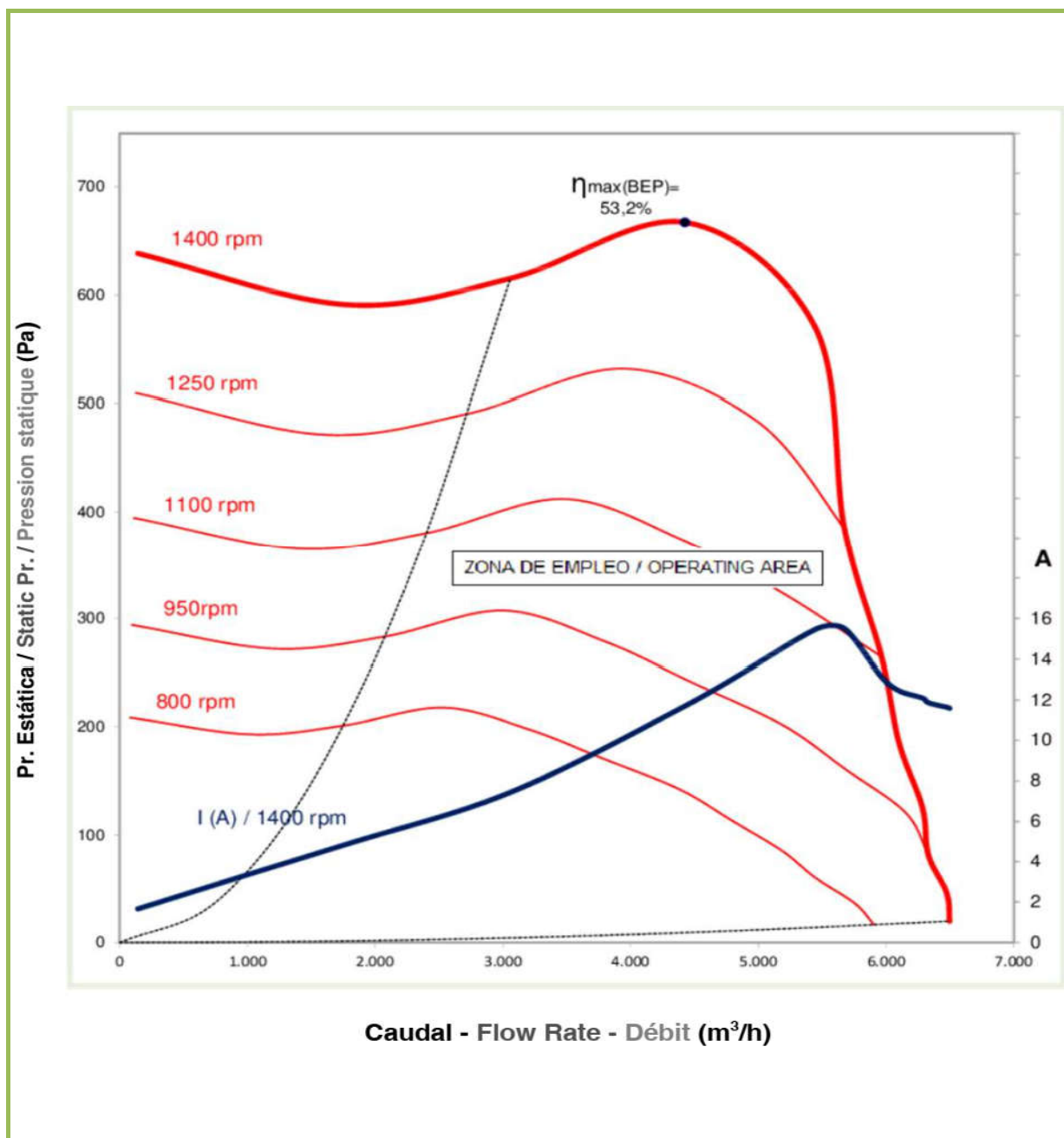

Max. electric power input	Revolutions Max	Intensity Max	Voltage Max	Max air flow	Max static pressure	Weight
P max W	RPM max (min <sup>-1</sup> )	I max (A) 220V 240V	Tension V -50 Hz	m <sup>3</sup> /h	Pa	Kg
2518	1400	15,5	230V±10%	6618	667,1	22,7



TMD EC 12/12-11

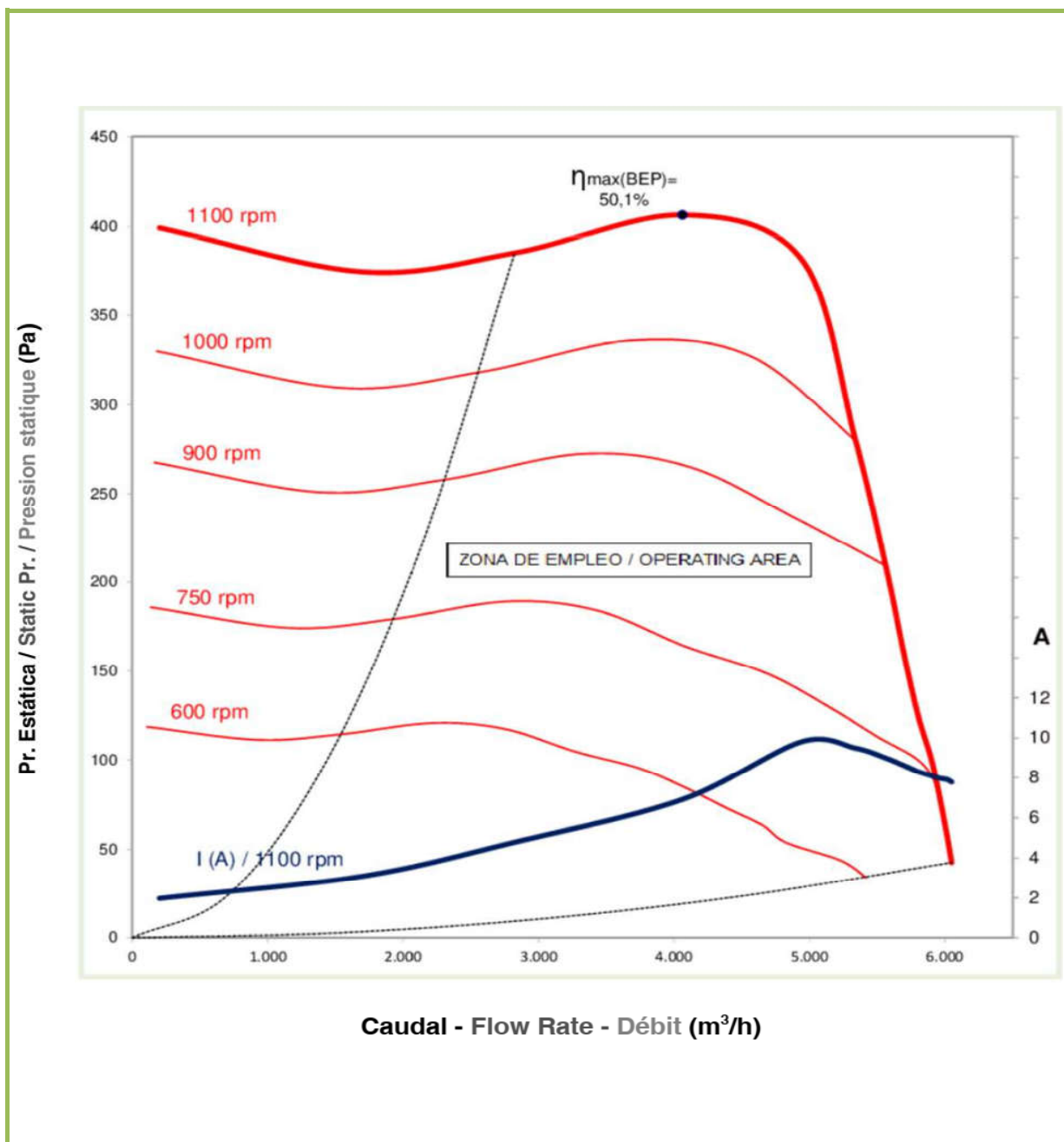

Max. electric power input	Revolutions Max	Intensity Max	Voltage Max	Max air flow	Max static pressure	Weight
P max W	RPM max (min <sup>-1</sup> )	I max (A) 220V 240V	Tension V -50 Hz	m <sup>3</sup> /h	Pa	Kg
1511	1100	9,8	230V±10%	6049	406,6	21,8



**TMD EC 12/12-14**

Max. electric power input	Revolutions Max	Intensity Max	Voltage Max	Max air flow	Max static pressure	Weight
P max W	RPM max (min <sup>-1</sup> )	I max (A) 220V 240V	Tension V -50 Hz	m <sup>3</sup> /h	Pa	Kg
2473	1400	15,1	230V±10%	7038	656,5	24

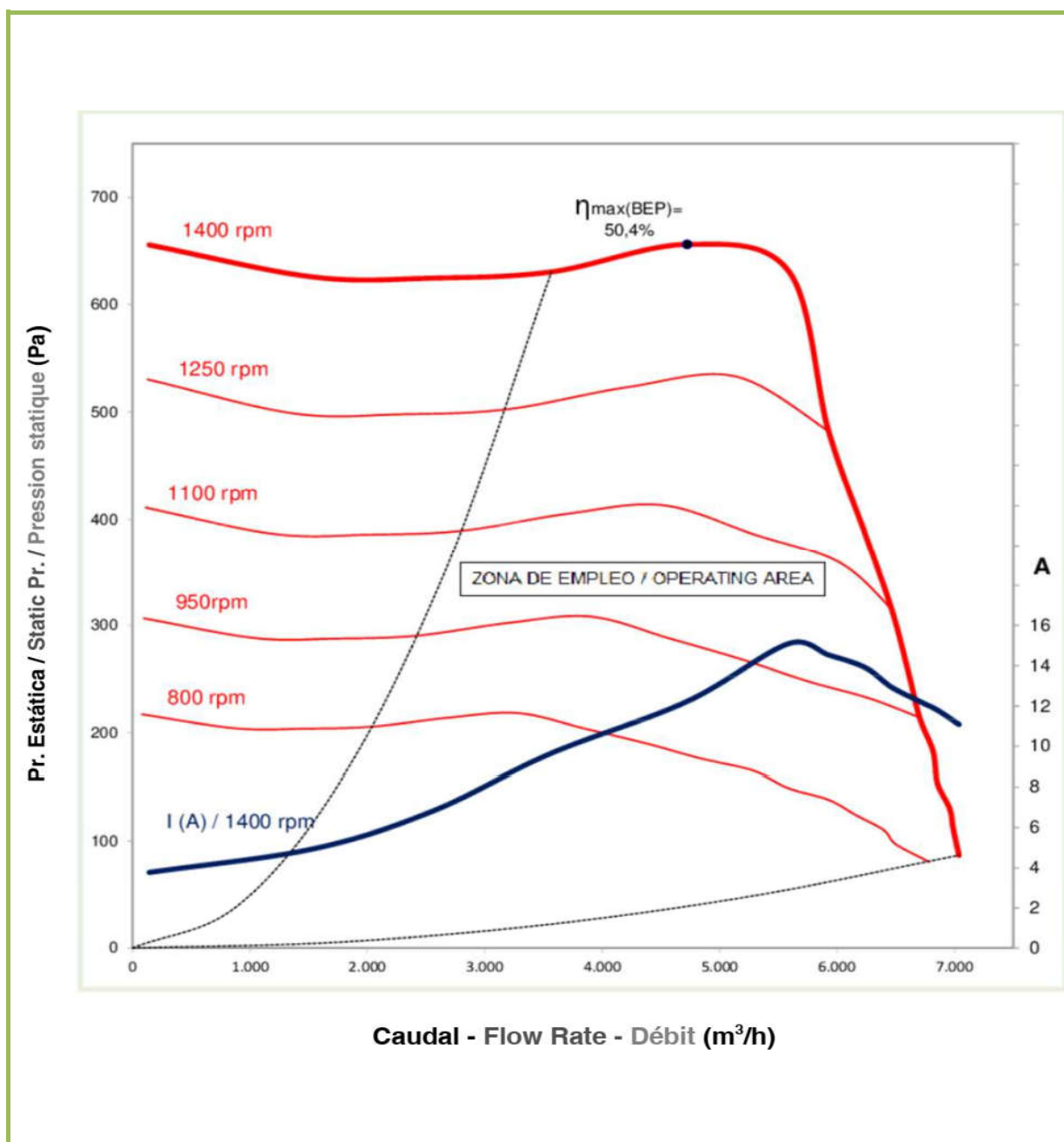

TMD EC 15/15-09



Max. electric power input	Revolutions Max	Intensity Max	Voltage Max	Max air flow	Max static pressure	Weight
P max W	RPM max (min <sup>-1</sup> )	I max (A) 220V 240V	Tension V -50 Hz	m <sup>3</sup> /h	Pa	Kg
1139	900	7,6	230V±10%	6716	438,5	35,5

